

PORTABLE FRIDGE/MOBILE COLD CHAIN

By Antech Scientific

2018

Company Profile



ANTECH Group is committed to offering high quality laboratory instruments and medical products while matching to the unique needs of customer. Our dedication is to provide quality instruments with lifetime care.

Antech Group sets its production facilities in 5 cities. The product lines include:

Cold storage – Cryogenic freezer, ULT freezer, deep freezer, pharmacy refrigerator, blood bank refrigerator, vaccine refrigerator, mortuary freezer and cold room

Cryogenic storage – liquid nitrogen freezer, liquid nitrogen container and Dewar vessel

Clean air product – biological safety cabinet, laminar flow cabinet (clean bench), air shower, sample booth, fan filter unit and clean room

Scientific instrument – fermenter, bio-reactor, freeze dryer, glassware washer, centrifuge, incubator and water purification system

Medical equipment & consumable - washer disinfectant, plasma sterilizer and dialyzer

In accordance to our unique business philosophy, we always remind ourselves to avoid any short-sighted activities and to focus on long-term success and growth.

We Antech team treat our customers as long-term partners & life-time friends. We are very clear that any of our success comes and will come from satisfaction of our partners and customers. "Quality instruments, lifetime care" is commitment to our partners, as well as to ourselves.



Company Certifications



Customers



Quality instruments, lifetime care

www.antechscientific.com



Category

01-06 Portable fridge/freezer

07-12 Mobile cold chain

13-14 Optional accessories



Portable fridge/freezer

Antech portable fridge/freezers offer rugged construction, innovative technology and powerful yet efficient cooling. Great for adding refrigerator or freezer space to any RV, car, truck, or boat. Never use bagged ice again and is great for camping, travel, transportation of medicines. Cooling compartment can be equipped with wire basket (optional).

- ◇ Elegant Design with Matt face;
- ◇ Ultra efficiency compressor;
- ◇ Can run on 12V/24V or 110~240V 50Hz/60Hz AC;
- ◇ Adjustable temperature from -20 °C ~ 10 °C;
- ◇ Fast pull down cooling to 0 °C within 30 minutes;
- ◇ Digital temperature controller and LCD display;
- ◇ 3-stage automatic power diagnose and cut off in case of over load to protect battery;
- ◇ Anti-Vibration design for Harsh Conditions.





- 
Car battery protection
- 
Shock-proof protection
- 
Energy efficient
- 
Anti-electro magnetic



Model	PRF-32
Capacity	32L
Temperature range	-20 C +10 C (32 C Ambient Temperature)
Working Condition	10 C ~45 C
Rated Voltage	DC 12V/24V/AC 100~240V/50Hz/60Hz
Rated Power	50W(+20%)
Cooling System	Ultra efficiency compressor/ SECOP compressor (Danfoss)(Optional)
Refrigerant	R134a
Foaming Agent	C5H10/C-Pentane
Net Weight	12.8kg
Gross Weight	15.4kg
Noise Level	≤40dB (A)
Cabinet Material	ABS+PP
Product Size	690*345*382
Package Size	708*398*449
Color	Dark Gray/Light Gray/black
Optional Accessories	Insulated Jacket,Basket, Logo Screen/Lithium battery



Model	PRF-42
Capacity	42L
Temperature range	-20 C +10 C (32 C Ambient Temperature)
Working Condition	10 C ~45 C
Rated Voltage	DC 12V/24V/AC 100~240V/50Hz/60Hz
Rated Power	50W(+20%)
Cooling System	Ultra efficiency compressor/ SECOP compressor (Danfoss)(Optional)
Refrigerant	R134a
Foaming Agent	C5H10/C-Pentane
Net Weight	13.5kg
Gross Weight	16.0kg
Noise Level	≤40dB (A)
Cabinet Material	ABS+PP
Product Size	690*345*462
Package Size	708*398*524
Color	Dark Gray/Light Gray/black
Optional Accessories	Insulated Jacket,Basket, Logo Screen/Lithium battery



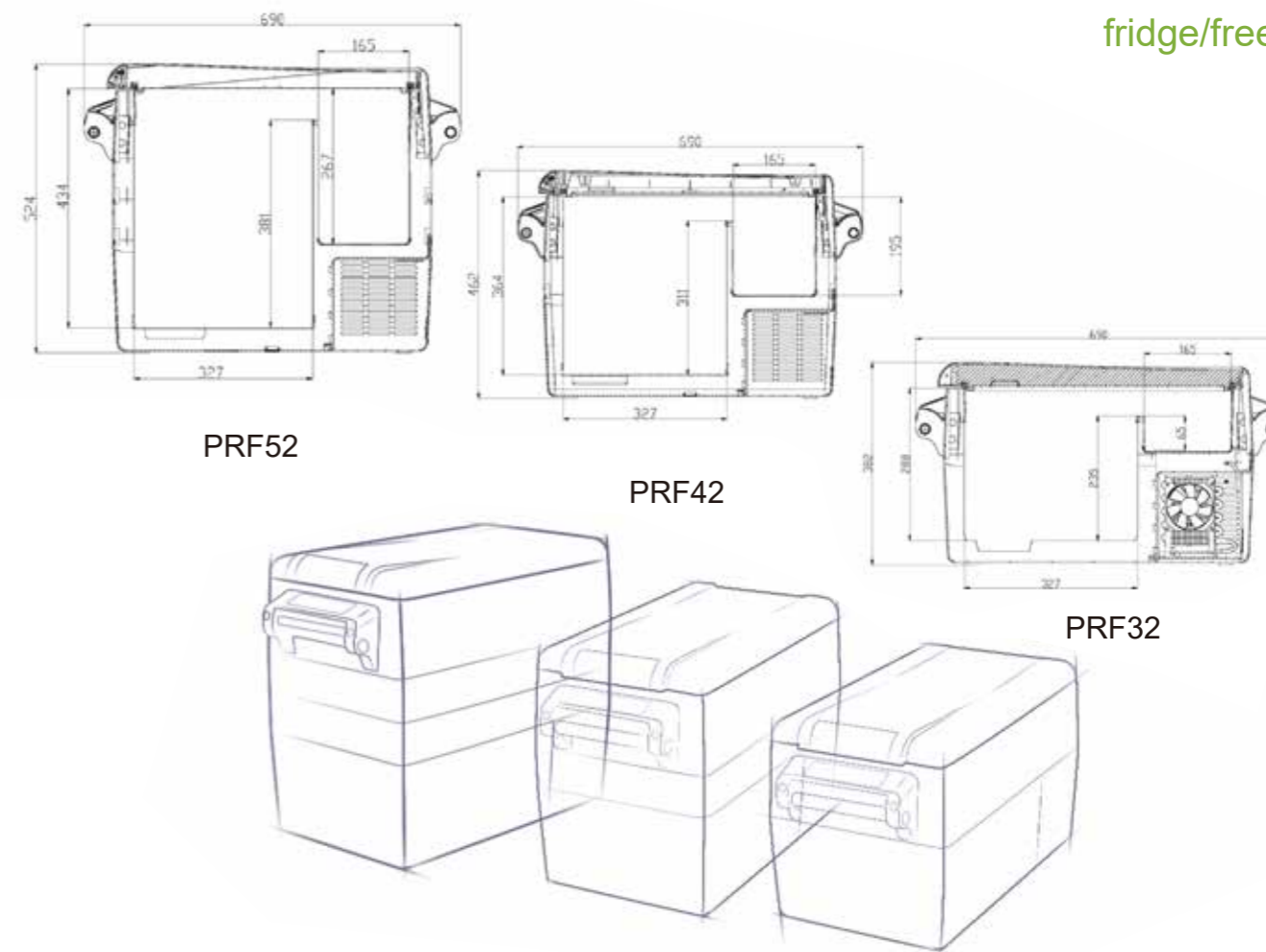

Model	PRF-52
Capacity	52L
Temperature range	-20 C +10 C (32 C Ambient Temperature)
Temperature Drop	52 C
Rated Voltage	DC 12V/24V/AC 100~240V/50Hz/60Hz
Rated Power	50W(+20%)
Cooling System	Ultra efficiency compressor/ SECOP Compressor(DANFOSS/optional)
Refrigerant	R134a
Foaming Agent	C5H10/C-Pentane
Net Weight	15.8kg
Gross Weight	17.7kg
Noise Level	≤40dB (A)
Cabinet Material	ABS+PP
Product Size	690*345*524
Package Size	708*398*599
Color	Dark Gray/Light Gray/black
Optional Accessories	Insulated Jacket,Basket, Logo Screen/Lithium battery





- 
Car battery protection
- 
Shock-proof protection
- 
Energy efficient
- 
Anti-electro magnetic

Mobile cold chain

Antech mobile cold chain offers premium quality and innovative cold chain solution to you. It is widely applied for Rvs, boats, campsites, medicine transportation. All you need is either a standard household AC power 100~240V 50Hz/60Hz or DC power 12/24V, like an automotive battery.

- ◇ Exquisite design ultra-large capacity;
- ◇ Dual zone model with two independent thermostats to control two independent compartments at the temperature of your choice;
- ◇ Smart digital controller ;
- ◇ 3-stage automatic power diagnose and cut off, in case of over load to protect the battery;
- ◇ High quality cabinet material to protect against deforming;
- ◇ High density foaming insulation to ensure longer hold over time;
- ◇ Ultra efficiency compressor;
- ◇ Anti-shake design;
- ◇ Can run with 12V/24V DC or 100~240V 50Hz/60Hz DC.





Dual rooms with two independent controllers



Model	PRF-75/95/115
Temperature range	-20 C+10 C (32 C Ambient Temperature)
Working condition	10 C-45 C
Rated Voltage	DC 12V/24V/AC100~240V 50/60Hz
Rated Power	70W(+20%)
Cooling System	Ultra efficiency compressor/SECOP Compressor (DANFOSS/optional)
Forming Agent	C5H10/C-Pentane
Noise Level	≤40dB(A)
Cabinet Material	Powder coated galvanized steel/Stainless steel (Optional)
Color	Dark Gray/Light Gray/white
Optional Accessories	Basket

Model	Capacity	Product Size	Packing Size	Net Weight	Gross Weight	Refrigerant
PRF75	75L	811*482*512	906*575*585	24.8Kg	29.5Kg	R134a
PRF95	95L	811*482*592	906*575*665	28.4Kg	33.1Kg	R134a
PRF115	115L	811*482*672	906*575*745	31.9Kg	36.6Kg	R134a



Model	PRF-80/100/125
Temperature range	-20 C+10 C (32 C Ambient Temperature)
Working condition	10 C-45 C
Rated Voltage	DC 12V/24V/AC100~240V 50/60Hz
Rated Power	85W(+20%)
Cooling System	Ultra efficiency compressor/SECOP Compressor (DANFOSS/optional)
Forming Agent	C5H10/C-Pentane
Noise Level	≤40dB(A)
Cabinet Material	Powder coated galvanized steel/Stainless steel (Optional)
Color	Dark Gray/Light Gray/white
Optional Accessories	Basket

Model	Capacity	Product Size	Packing Size	Net Weight	Gross Weight	Refrigerant
PRF80	80L	872*516*506	965*605*575	28Kg	32.7Kg	R134a
PRF100	100L	872*516*586	965*605*655	30.5Kg	35.2Kg	R134a
PRF125	125L	872*516*653	965*605*735	33Kg	39.1Kg	R134a



Model	PRF-45/60
Temperature range	-20 C +10 C (32 C Ambient Temperature)
Working condition	10 C -51 C
Rated Voltage	DC 12V/24V/AC100~240V 50/60Hz
Rated Power	70W(+20%)
Cooling System	SECOP Compressor(DANFOSS)
Forming Agent	C5H10/C-Pentane
Noise Level	≤40dB(A)
Cabinet Material	Powder coated galvanized steel/Stainless steel (Optional)
Color	Dark Gray/Light Gray/White
Optional Accessories	Basket

Model	Capacity	Product Size	Packing Size	Net Weight	Gross Weight	Refrigerant
PRF45	45L	621*485*469	718*578*550	20.8Kg	22.9Kg	R134a
PRF60	60L	621*485*569	718*578*650	23.3Kg	25.4Kg	R134a



ACCESSORIES



Vehicle power connector



Power adapter



Jacket



Lithium battery



Basket



Vaccine digital thermometer
(sensor in glycol bottle)



	Vaccine/Medicine	5 °C		Vegetables	8 °C
	Drinks	5 °C		Prepared food	3 °C
	Juice	8 °C		Meat	-18 °C
	Red wine	13 °C		Seafood	-3 °C
	Fruit	8 °C		Quick-frozen food	-18 °C